

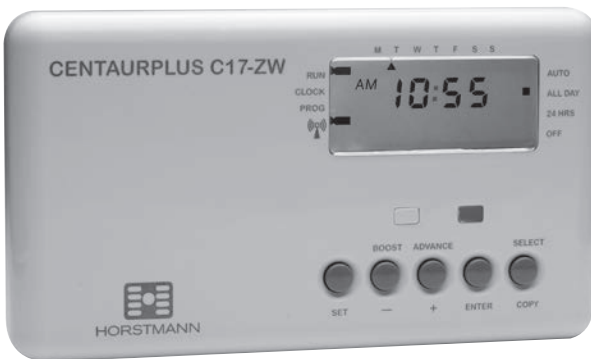

HORSTMANN

CentaurPlus ZW and HRT4-ZW Installation Instructions

Combined Time Control and Room Thermostat



The Horstmann CentaurPlus ZW combined wireless room stat and timeswitch allows a combi boiler system to have a room thermostat added without the need for any additional wiring.

Replacing the existing timeswitch with the CentaurPlus ZW will allow the room thermostat to be connected wirelessly producing immediate energy savings in houses where no previous room thermostat has been fitted.

The device is intended to upgrade existing combi boiler systems that do not have an existing room thermostat. It is not intended for new installations where it will be necessary to install two heating zones in order to comply with current Building Regulations.

For the installer

Installation and connection should only be carried out by a suitably qualified person and in accordance with the current edition of the IEE wiring regulations.

WARNING: Isolate mains supply before commencing installation.

An example circuit diagram for a typical combi boiler installation is shown below. This diagram is schematic and should be used for guidance only.

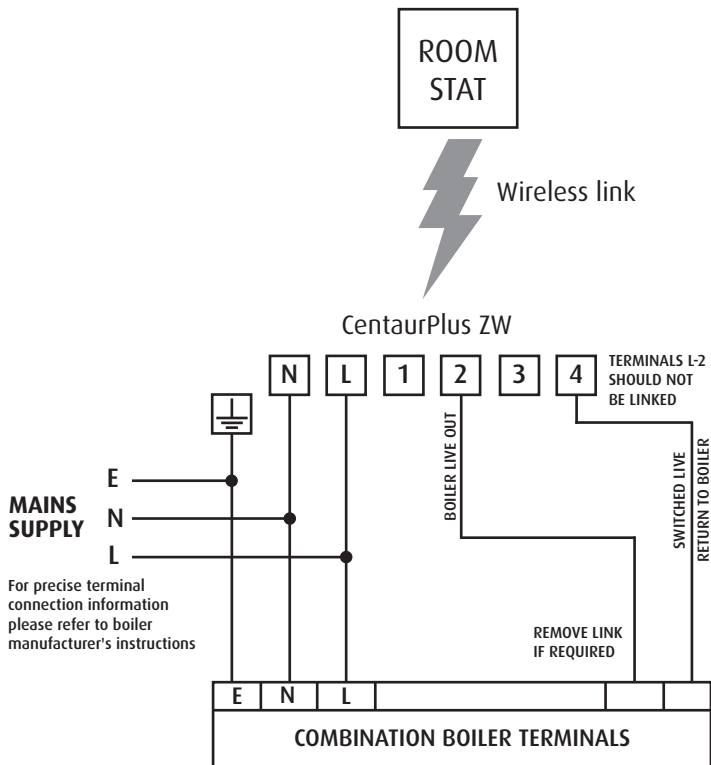

Fitting the backplate

Once the backplate has been removed from the packaging please ensure the timeswitch is re-sealed to prevent damage from dust, debris.

The backplate should be fitted with the wiring terminals located at the top and in a position that allows a total clearance of at least 50mm around the unit.

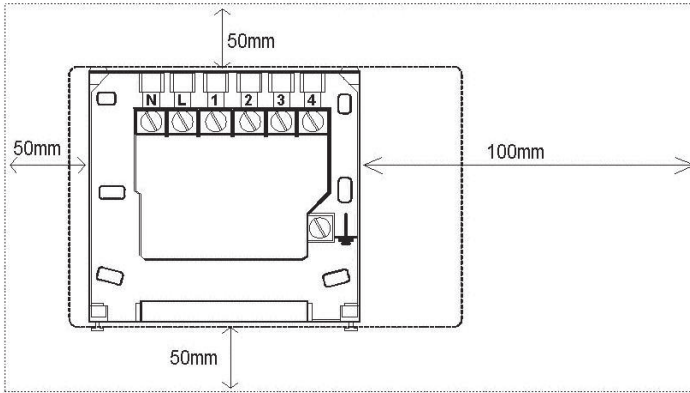

Direct wall mounting

Offer the backplate to the wall in the position where the timeswitch is to be mounted, remembering that the backplate fits to the left hand end of the control. Mark the fixing positions through the slots on the backplate (fixing centres of 60.3mm), drill and plug the wall, then secure the plate in position. The slots in the backplate will compensate for any misalignments of the fixings.

Wiring box mounting

The backplate may be fitted directly onto a single gang steel flush wiring box complying with BS4662, using two M3.5 screws. CentaurPlus controls are suitable for mounting on a flat surface only; they must not be positioned on a surface mounted wall box or on unearthed metal surfaces.

Electrical Connections

All necessary electrical connections should now be made. Flush wiring can enter from the rear through the aperture in the backplate. Surface wiring can only enter from beneath the timeswitch and must be securely clamped. The mains supply terminals are intended to be connected to the supply by means of fixed wiring. Recommended cable sizes are 1.00 or 1.5mm.

CentaurPlus timers are double insulated and do not require an earth connection but an earth connection is provided on the backplate for terminating and cable earth connectors. Earth continuity must be maintained and all bare earth connectors must be sleeved. Ensure no earth conductors are left protruding outside the central space enclosed by the backplate.

Internal diagram - C17-ZW

The CentaurPlus ZW has voltage free contacts. A link L-2 is required for mains voltage applications

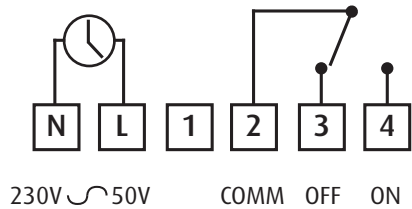

Rear view of CentaurPlus timeswitch

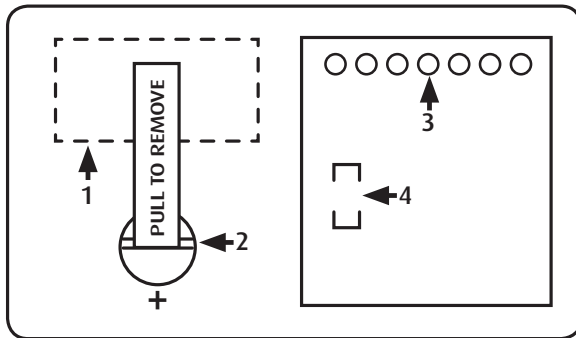

- 1 - RATINGS LABEL
- 2 - BATTERY
- 3 - CONNECTOR PINS
- 4 - PRODUCTION DATE LABEL

Battery reserve

The battery must be commissioned prior to fitting the timeswitch to the backplate. This is achieved by the means of a commissioning strip situated in the back of the unit. Pull out the battery commissioning strip at the back of the timeswitch and re-insert the battery; the reserve is now activated. When the timeswitch is running the battery reserve clock display will disappear. This is to prolong the life of the battery.

Fitting the timeswitch

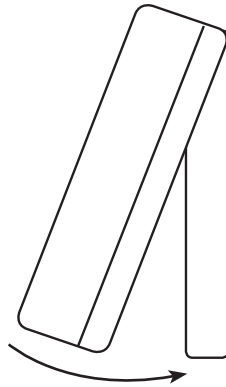

End view of CentaurPlus timer

If surface wiring has been used, remove the knockout/insert from the bottom of the timeswitch to accommodate it.

Loosen the two 'captive' retaining screws on the bottom of the backplate. Now fit the timeswitch to the backplate, ensuring the lugs on the backplate engage with the switch.

Swing the bottom of the timeswitch into position ensuring that the connection pins on the back of the unit locate into the terminal slots in the backplate.

Tighten the two captive retaining screws to fix the unit securely.

Then switch on the mains supply.

On completion of the installation please reset the timeswitch as detailed next;

Resetting the timeswitch

On the CentaurPlus press the SET and SELECT buttons together. Then release the buttons and the timer will return to preset factory settings

The preset factory settings are illustrated on page 10 of the USER GUIDE.

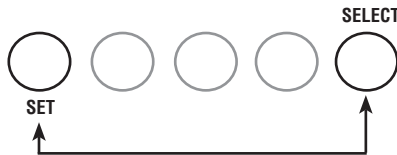

The unit is now ready to be signed on to its HRT4-ZW room thermostat, to suit the user's requirements

General Information

BATTERY

The timeswitch is fitted with a non-rechargeable, long life battery, which will maintain the programmed time settings for a minimum of ten months with the supply disconnected. THIS SHOULD BE SUFFICIENT TO COVER POWER INTERRUPTIONS DURING THE LIFE OF THE UNIT. During power interruptions the display will be blank, after 3 days the current time of day will be lost. These measures are to prolong the battery life.

SERVICE AND REPAIR

This timeswitch is NOT user serviceable. Please do not dismantle the unit. In the unlikely event of a fault developing please refer to the **RESETTING THE TIMESWITCH** section of this user guide shown above. If this fails to resolve the problem please contact your installer, a local heating engineer or a qualified electrician.

HRT4-ZW room thermostat

Installation and pairing instructions



The HRT4-ZW is a wireless electronic battery powered room thermostat that uses interoperable two-way RF mesh networking technology to provide optimum comfort with close control of the energy used to heat the home without the need for additional wiring or unsightly cable runs.

The HRT4-ZW will only operate when 2 x AAA batteries have been fitted and the thermostat is installed and communicating with the CentaurPlus ZW timer/receiver unit.

INSTALLATION AND CONNECTION OF THE HRT4-ZW SHOULD ONLY BE CARRIED OUT BY A SUITABLY QUALIFIED PERSON.

Instructions for pairing the HRT4-ZW room thermostat with the CentaurPlus ZW.

These devices use the latest Z-Wave wireless communication technology to give a reliable wireless link that should not suffer from interference from other nearby devices. The device comprises a thermostat (the HRT4-ZW) and its receiver (the CentaurPlus C17-ZW). Pairing the devices on site ensures reliable communication.

Follow these steps to ensure that the HRT4-ZW thermostat will communicate satisfactorily with its receiver. This is best carried out with the HRT4-ZW thermostat held nearby the (powered) CentaurPlus C17-ZW.

Stage 1

1) Set the number 1 DIL switch on the back of the HRT4-ZW thermostat to the On (Up) position and the display will change to show the letter 'I'. If the letter 'L' appears, carry out stage 1A opposite.

2) Power up the CentaurPlus ZW timeswitch.

3) Press the dial on the front of the HRT4-ZW thermostat once so that the 'I' in the display flashes.

4) Press and hold the 'Boost' and 'Enter' buttons on the front of the CentaurPlus ZW until an indicator appears in its display against the radio aerial symbol.

5) After a few seconds the radio mast symbol  will appear in the display along with the letters IP.

6) Reset the number 1 DIL switch on the back of the HRT4-ZW to the Off position and the temperature will appear in the display.

7) Now check the CentaurPlus ZW time control is receiving signals from the thermostat by turning the time switch to an 'On' setting with the red indicator light lit and turning the thermostat up and down to make the boiler switch on and off.

N.B. There is a half second delay in switching On and Off on receipt of the commands. There is no 'click' from the thermostat which is silent in operation but there will be an audible 'click' from the CentaurPlus ZW when it is 'On' and the thermostat switches On and Off.

8) When the thermostat is calling for heat a flame symbol will appear in its display.

9) Z Wave communication is now successfully established.

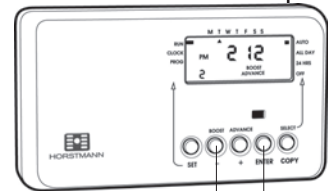
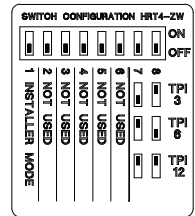

Press and hold 'BOOST' and 'ENTER' buttons to 'SIGN ON' or 'PAIR' the HRT4 ZW thermostat

Stage 1A – Only used if ‘L’ is displayed instead of ‘I’

- 1) Turn the dial of the HRT4-ZW until the letter P appears in the display.
- 2) Press the dial twice and PP should appear in the display.
- 3) Turn the dial until the letter ‘I’ appears in the display and return to the main instruction.

Under normal circumstances the HRT4-ZW thermostat and CentaurPlus C17 ZW will be ‘paired’ easily by following the procedure shown under Stage 1 of the pairing instructions

Only use Stage 2 if a radio link cannot be successfully established between the two devices.

Stage 2 – Only used if the above procedure does not establish a successful communication link

- 1) Turn the dial of the HRT4-ZW until the letter P appears in the display.
- 2) Press the dial twice and PP should appear in the display.
- 3) Now turn the dial until letter E appears in the display.
- 4) Press the dial once and the display should flash ‘E’.
- 5) Press and hold the ‘Boost’ and ‘Enter’ buttons on the CentaurPlus ZW.
- 6) Turn the thermostat dial until ‘I’ appears in the display and return to the main instruction.

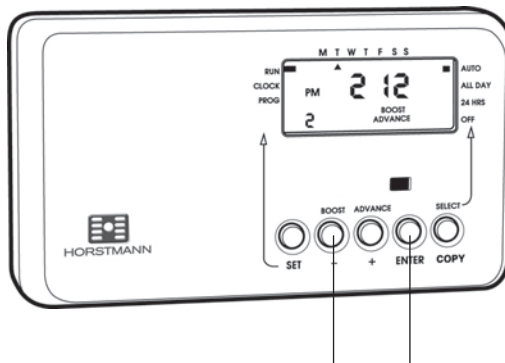

Press and hold ‘BOOST’ and ‘ENTER’ buttons to ‘SIGN ON’ or ‘PAIR’ the HRT4 ZW thermostat

Fitting the HRT4-ZW Room Thermostat

Before final installation it is advisable to commission the product and ensure that the Thermostat and Receiver are communicating satisfactorily. First install the 2 type AAA batteries provided making sure that they are fitted correctly as indicated by the markings in the battery compartment.

Once the thermostat and receiver are successfully 'paired' the thermostat can be installed in its correct location. Please see Z-Wave pairing instructions on page 8.

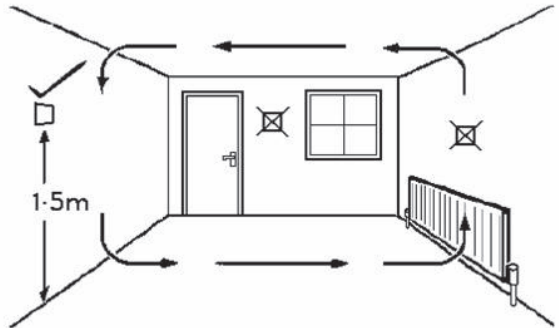

Avoid installing the thermostat against or behind any large metal surfaces which could interfere with the radio signals to and from the CentaurPlus timer with combined receiver. The HRT4-ZW should be mounted on an internal wall approximately 1.5 metres from floor level using the wall plate provided and should be in a position away from draughts, direct heat and sunlight. Ensure that there will be enough space to allow easy access to the two retaining screws located at the base of the wall plate.

Before fixing the wall plate in position check to see that the thermostat and boiler are still able to communicate satisfactorily by turning the thermostat temperature up and down to switch the boiler on and off.

Offer the plate to the wall in the position where the CentaurPlus ZW is to be mounted and mark the fixing positions through the slots in the wall plate. Drill and plug the wall, then secure the plate into position. The slots in the wall plate will compensate for any misalignment of the fixings.

Complete the installation by swinging the room thermostat into position by engaging with the lugs at the top of the wall plate before pushing it carefully home into its plug-in terminal block. Tighten the 2 captive screws on the underside of the unit.

Now ensure that the heating system is responding to the ON/OFF commands from the Room Thermostat and explain its operation to the householder before handing over the User Instructions.

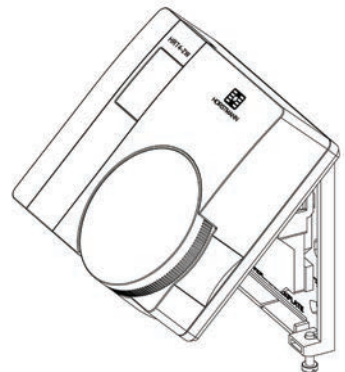

Timeswitch specification CentaurPlus ZW

Contact Rating 3 (1) Amps 230V AC

Contact Type Micro-disconnection changeover

Voltage free

Supply 230V AC 50Hz only

Pollution Degree 2

Class A Software Type 1 Control

Operating Temperature Range 0°C to +40°C

Battery Life 10 months continuous operation (minimum)

Case Material Thermoplastic, flame retardant

Dimensions 84mm x 150mm x 29mm

Display Back lit liquid crystal

Clock 12 hour AM/PM

Auto BST/GMT changeover

Displayed Time adjustments 1 minute steps

Switched Time adjustments

Operating periods per day - 3 per day (Separate programmes possible for each day of the week)

10 minute steps

Override 1 hour boost, 1 hour extension to On period, instant advance

Mounting Industry standard 6 terminal plug in wall plate

Transmitter Frequency 868MHz

Design Standard EN60730-2-7

IP30

EN300-220 R & TTE Directive

EN301-489

Thermostat specification HRT4-ZW

Power supply 2 x AAA alkaline batteries

Temperature accuracy +/- 0.5°C

Transmitter frequency 868MHz

Dimensions 86mm x 86mm x 36.25mm

Pollution control Degree 2

Design standard EN60730 - 2-9

Temperature range 5°C – 30°C

Enclosure protection IP30

Operating temperature range 0-40°C

Case material Thermoplastic, flame retardant

For further replacement timeswitch exchange information, please see the 'Programmer Wiring and Replacement Guide' at www.horstmann.co.uk
Use the categories shown under CentaurPlus C11 and C17.



HORSTMANN

Horstmann Controls

South Bristol Business Park, Roman Farm Road, Bristol BS4 1UP

E-mail: sales@horstmann.co.uk

Web site: www.horstmann.co.uk

